

# INOVA-EX

Model No. **AB-IVFB AB-IVFS**  
**AB-IVFT AB-IVFW**

## Operating Manual

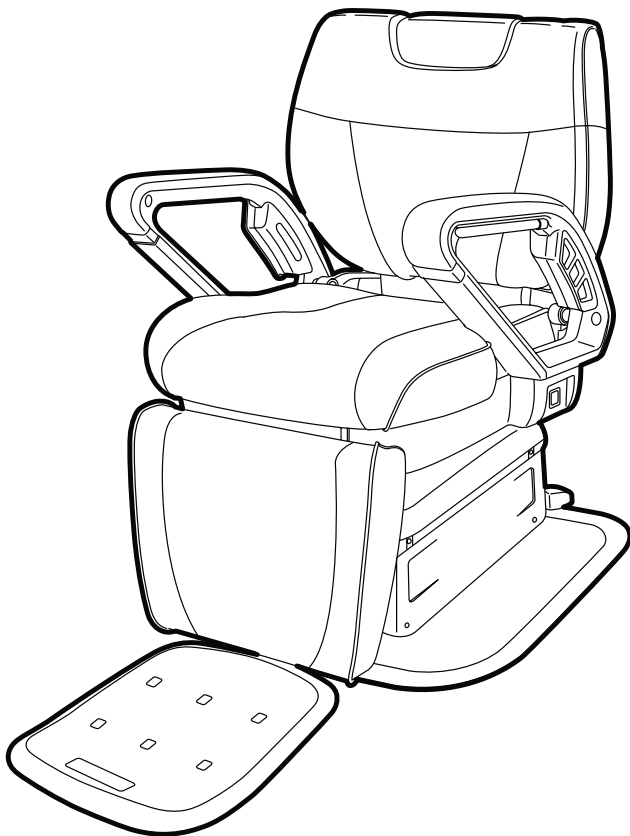

Thank you for purchasing TAKARA BELMONT product.

**Please read through this manual and warranty carefully before installing or using the product to ensure correct use.**

Failure to read the operating manual may lead to accidents. This product is designed for commercial use at barbers or beauty salons. Do not use this product for the purposes other than the practices and services in these places. Keep this operation manual in a safe place for your future reference.

Please contact us in case your operating manual is unreadable due to being soiled or ripped, or is lost.

## Table of Contents

<b>General Safety Instructions</b>	<b>1</b>
<b>Safety Precautions (Be sure to observe them)</b>	<b>1</b>
<b>Notes for Use</b>	<b>3</b>
<b>Position of Warning Label</b>	<b>4</b>
<b>Notes for Use with Upholstery (artificial and natural leather)</b>	<b>4</b>
<b>Accessories</b>	<b>4</b>
<b>Name of Components</b>	<b>5</b>
<b>Preparation</b>	
Power Supply	<b>7</b>
<b>How to Use</b>	
(1) Using the Rotation Lock Switch and Cape Holder	<b>8</b>
(2) Raising/Lowering Chair	<b>10</b>
(3) Adjusting the Headrest, Backrest, and Legrest	<b>11</b>
(4) Preset Function and Auto Return Function	<b>14</b>
(5) Using the Removable Step (AB-IVFW)	<b>15</b>
(6) Using the Dryer Holder	<b>16</b>
(7) Detaching the Backrest (The Backrest (upper) removable model) AB-IVFS and IVFW	<b>16</b>
(8) Using Service Outlet	<b>17</b>
<b>Care and Maintenance</b>	<b>18</b>
<b>Daily Inspection</b>	<b>19</b>
<b>Troubleshooting</b>	<b>19</b>
<b>Daily Inspection Procedure</b>	<b>20</b>
<b>Specifications</b>	<b>21</b>
<b>Standard Period of Use</b>	<b>22</b>
<b>When Disposing of This Product</b>	<b>22</b>

# General Safety Instructions

## ■ Before use



Please read the safety precautions and notes carefully to ensure the proper use of this product.

## ■ Intended users of this product

Users who do not have licenses of barber or/and hairdresser cannot use this product.

## ■ About the precautions listed here

These precautions are provided for the safe use of this product and to prevent personal injury and harm to users and third parties. Please follow all of the precautions shown here, as they contain important information related to safety. TAKARA BELMONT bears no responsibility for personal injury or harm caused to the user or third parties in the event that the "Safety Precautions", "Notes for Use" or the "Notes for Use with Upholstery (artificial and natural leather)" have not been observed and an accident has occurred. In this event, the user who did not follow these precautions bears responsibility for said personal injury. Detailed information on cautionary marks is as explained below. Be sure to read and understand their descriptions carefully before reading the main text.

Classification of precautions	Size and degree of imminent danger or harm
 <b>Warning</b>	This mark warns the user that "ignorance of this display and improper use may cause death or serious personal injury".
 <b>Caution</b>	This mark warns the user that "ignorance of this display and improper use may cause slight to moderate personal injury or property damage".

# Safety Precautions (Be sure to observe them)

## Warning

### ● Do NOT share the outlet with other appliances

Use an outlet of 230 VAC (7A or higher)\* with a grounding terminal. Do not share the outlet with other appliances. Many loads will cause overheat and fire.

※240 VAC (7A or higher), 220 VAC (7A or higher), 120 VAC (12A or higher), and 110 VAC (12A or higher)

### ● Do NOT use the equipment if the power cord or/and the power plug are damaged

Do not use the equipment if the power cord or/and the power plug are damaged, or the power cord is not plugged completely to the end. It may cause electric shock or/and fire.

### ● Insert the power plug completely to the end

Always insert the power plug completely and firmly into the outlet. Incomplete insert may cause short or overheat leading to fire.

### ● Unplug the power cord when not used

Be sure to turn off the power and unplug the power cord from the outlet. Accidental operation may cause unpredictable accidents or insulation degradation may lead to fire caused by a short circuit.

### ● The customer's or user's hands, fingers, or body parts must be kept away from the movable parts of the equipment or the area surrounding its movable parts

If not, this may result in the body part being pinched, causing bodily injury.

### ● Be sure to ground the product

If not grounded or inappropriately grounded, there may be a risk of electric shock when electric failure or electric leakage occurs. Contact a qualified installer for grounding.

### ● Do NOT unplug the power cord by pulling on the cord

Do not unplug the power cord by pulling on the cord. Instead hold the power plug when plugging or unplugging. Or the cord is damaged and electric shock or/and fire may occur.

### ● Do NOT splash water over the product for cleaning

Since this is electrical product, do not splash water over the product for cleaning. It may cause failures or electric shock.

### ● Do NOT step up to the tip of the step

Do not step up to the tip of the step. The chair may be toppled or the step may move suddenly, which causes bodily harm or property damage.

### ● Caution at handling

Do not lift the front portion of the seat, the seat portion will break and it may cause bodily harm or property damage. Please refer to the installation manual.

# Safety Precautions (Be sure to observe them)

## Warning

### ● Care must be taken under environment with electromagnetic interference waves

This product may malfunction under environment with electromagnetic interference waves. Do not install this product near equipment generating electromagnetic waves such as communication equipment, elevator. Do not use devices generating electromagnetic waves such as cell phone around this product.

### ● Be careful during installation

- Have installation or mounting of the equipment performed by a professional (from us or our specified representative).
- The chair must be installed on flat and solid flooring.
- If the chair is installed to an area where the flooring surface is inclined at 5° or more, it may cause the chair to fall over.

### ● When operating the chair, mind the surrounding area

Before or during operation of the chair, sufficient care must be taken to ensure that bodies, hands, feet, or/and obstructions are not around the operating range (up/down directions of the chair, backrest and legrest, and rotating directions of the chair). If care is not taken to do so, it may result in being pinched by the chair, and may cause bodily harm or property damage.

### ● Care must be taken when your customers step up to or step down from the chair

Be sure the chair rotation is locked when your customers step up to or step down from the chair. Especially when a customer steps up to or steps down from the chair from/to a wheel chair, be sure that there is no wheel chair around the operating range of the chair. When feet or casters hit any of the foot switch, the chair moves suddenly. It may cause bodily harm or property damage.

### ● Care must be taken when setting the preset position

When setting the presetting position, before or during setting, sufficient care must be taken to ensure that bodies, hands, feet, or/and obstructions are not around the operating range. If care is not taken to do so, it may result in being pinched by the chair, and may cause bodily harm or property damage.

### ● Care must be taken after changing the preset position

After changing the preset position, sufficient care must be taken to ensure that bodies, hands, feet, or/and obstructions are not around the operating range. If care is not taken to do so, it may result in being pinched by the chair, and may cause bodily harm or property damage.

### ● Do NOT apply excessive weight to the legrest or armrest

Do not sit on the legrest or armrest. Also, do not apply more than the necessary weight to the chair. Doing so may cause the chair to fall over or break.

### ● Care must be taken with customers and children

Care must be taken to supervise customers in order to prevent an unintended accident caused by a customer (especially children) playing with or operating the chair in a careless manner.

### ● Do NOT sit anywhere except the designated sitting area

Never sit on the headrest, armrest, or on the front edge of the backrest, the legrest, and the step when the backrest has been reclined or the legrest has been raised. Also, do not apply more weight to those parts than necessary. Doing so may cause the chair to fall over or break.

### ● Be careful when reclining or raising the backrest

When reclining or raising the backrest, take sufficient care to ensure that customers' fingers or other objects are not between the backrest and the seat. Not doing so may result in bodily injury from pinching or other such accidents.

### ● Do NOT sit on the backrest

Sitting on the backrest may result in bodily injury or may cause the chair to break from falling over.

### ● Do NOT let your customers lie face down

Do not let your customers lie face down. If the chair moves suddenly, it may cause bodily harm.

### ● Disassembly and repair should only be performed by a skilled technician

Do not attempt to disassemble or repair the equipment on your own. To do so might cause electric shock during disassembling or repairing, a fire due to improper repair, or malfunction resulting in severe injury.

### ● Do NOT ground the product to:

- Water pipe  
Hard plastic is used for many pipes, and it is not possible to ground to them completely.
- Gas pipe  
There are risks of explosion or/and fire.
- Lightning rod and telephone cable.

### ● When the power goes down

- To avoid unpredictable move of chair when the power comes back on, turn off the main switch and unplug the power cord from the outlet. Also turn off the main switches of all appliances connected to the service outlets and unplug their power cords.
- If the seat position is raised (e.g., position at shampoo) when the power goes down, it is impossible to lower the seat. Utmost care (e.g., support your customers) must be taken when your customers have to go up to/down from the chair set at the raised position so that your customers are not injured or the chair doesn't fall over.

### ● Care must be taken when turning the chair

After turning the chair, make sure to lock (stop) the chair's turning by depressing rotation lock switch. Especially while the backrest is reclined, pay attention to lying position and movements of body, hands and legs of customer, and make sure of customer's safety before turning the chair. Before using automatic operation, confirm the chair rotation is locked. The chair's sudden move may cause bodily harm or property damage. Care must be taken so that adjuster under the step will not touch the power cord or the chair will not be toppled even if someone steps up to the step.

# Safety Precautions (Be sure to observe them)

<b>Caution</b>	
<ul style="list-style-type: none"> <li>● <b>Do NOT let persons weighing 135kg or more sit in the chair</b> Doing so may result in a falling accident or cause malfunction.</li> </ul>	<ul style="list-style-type: none"> <li>● <b>Be sure to turn on or off the power switch by hand</b></li> </ul>
<ul style="list-style-type: none"> <li>● <b>Before operation, confirm that every part is working normally and safely</b></li> </ul>	<ul style="list-style-type: none"> <li>● <b>Watch your step so that you aren't caught by the power cord</b></li> </ul>
<ul style="list-style-type: none"> <li>● <b>Make sure that there are no people's hands, feet, or obstructions between the step and floor when raising, lowering, or rotating the chair</b></li> </ul>	<ul style="list-style-type: none"> <li>● <b>Turn off the power switch after using the chair</b></li> </ul>
<ul style="list-style-type: none"> <li>● <b>If water or chemical solutions have been splashed on the chair, wipe it off immediately</b> Chemical solution may make a stain or if the solution is splashed on the electrical components, it may result in malfunction or electrical leakage. If water or chemical solutions has adhered to the chair, wipe it off immediately with a dry, soft towel, etc.</li> </ul>	<ul style="list-style-type: none"> <li>● <b>When wiping, strong disinfectants that corrode metal (povidone-iodine (isodine solution) or sodium hypochlorite, etc.) must never be used</b> Doing so may lead to malfunction.</li> </ul>
<ul style="list-style-type: none"> <li>● <b>Care must be taken when operating switches</b> Operators must take care of people around the chair. Before operating the chair, let them know the chair is going to be operated.</li> </ul>	<ul style="list-style-type: none"> <li>● <b>Conduct inspection paying attention to backlash, wobble, tilt, vibration, sound, heat and smell</b> When feeling any abnormality, stop using the chair immediately, unplug the power cord, and contact your dealer or us.</li> </ul>
<ul style="list-style-type: none"> <li>● <b>Use automatic operation after confirming safety around the chair</b> Before using automatic operation, confirm the customer is sitting on the designated sitting area of the chair. During operation, keep watching the customer.</li> </ul>	<ul style="list-style-type: none"> <li>● <b>Do NOT pound or scrape the equipment</b> Doing so may lead to the destruction or malfunction of the cover or other such parts.</li> </ul>
<ul style="list-style-type: none"> <li>● <b>Do NOT put things on the power cord</b> Do not put things on the power cord. It may damage the cord resulting in electric shock or fire due to disconnection or short.</li> </ul>	<ul style="list-style-type: none"> <li>● <b>When operating the headrest, take care to prevent your fingers and other body parts from being caught in the space around the operation lever or pinched between the headrest and the backrest</b></li> </ul>
<ul style="list-style-type: none"> <li>● <b>Please be careful, as the headrest will come off when raised too high</b></li> </ul>	<ul style="list-style-type: none"> <li>● <b>When the circuit breaker (the power switch) is often thrown, please call the service center</b></li> </ul>

# Notes for Use

<ul style="list-style-type: none"> <li>● <b>Recline the chair at the end of the day</b> Lower the seat and fully recline the backrest after the work of the day. Doing this can ease the load on the springs and the cylinders, and extend the product life.</li> </ul>	<ul style="list-style-type: none"> <li>● <b>Do NOT put things other than people on the seat</b> Putting things other than people may cause deformation, tearing, or corrosion of the upholstery.</li> </ul>
<ul style="list-style-type: none"> <li>● <b>Do NOT clean using chemicals or apply heat</b> If any chemicals are splashed on the upholstery or the pump cover, wipe off the chemical immediately. Splashed chemicals may cause discoloration or deterioration.</li> </ul>	<ul style="list-style-type: none"> <li>● <b>The maximum load is 1350 N (135 kgf). The raising speed may become slow if the load is nearly the maximum.</b></li> </ul>

## Position of Warning Label

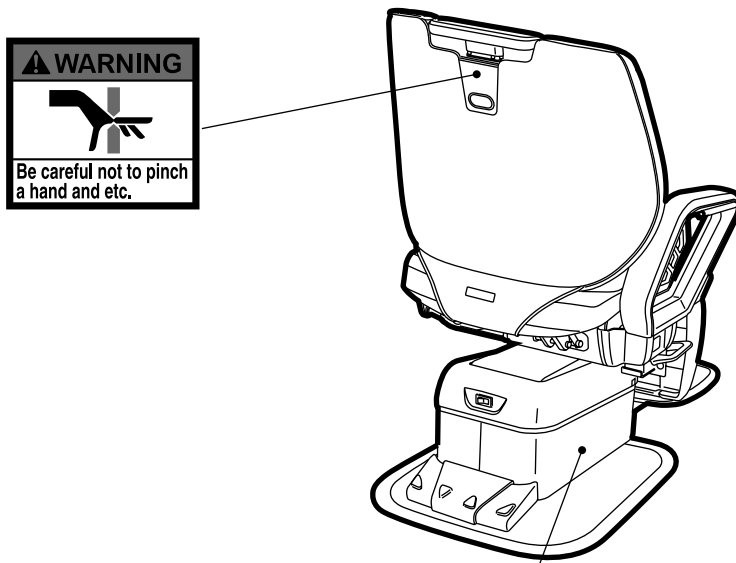

<b>WARNING</b>	<b>WARNING</b>	<b>WARNING</b>	<b>WARNING</b>
Risk of pinching during the operation. Check the space below and around the chair when raising or lowering the chair and the legrest.	Risk of dropping of the pump. Carry the chair with holding the base and the foot switch.	Risk of malfunction or a fire caused by a short circuit. Unplug the power cord when not used.	Risk of electric shock, fire, and abnormal motion. Do not disassemble, repair or modify.

Refer to the Operation Manual for other notes.

## Notes for Use with Upholstery (artificial and natural leather)

- Adherence of fabric dyes  
The upholstery may be stained by coming into contact with fabric, belts or other such attire. In order to avoid infiltration by plasticizer when color has been adhered, apply a solution of neutral detergent diluted by about 10% to a soft towel and wipe off the color as soon as possible. After wiping off the color, wipe the area dry.
- Caution for deterioration and color staining caused by contact
  - Contact with things such as other plastic parts, paints, solvents, and adhesive tape may cause changes to the surface shine, cracking, deformation, or peeling.
  - Contact with newspaper or printed materials may cause color staining.
  - Contact with T-shirt prints, jeans and other such items may cause color staining from dyes in the upholstery.
  - Contact with things like benzene, polish remover, or alcohol may cause the surface to discolor, dissolve, harden, soften, peel, extract plasticizer, or experience changes to its shine.
  - Using bleach or sheets that use bleach may cause discoloration or changes to shine.
  - When placed next to a source of excessive heat such as an iron or heater, deformation or discoloration may occur.
  - Shield the upholstery with a curtain or other such item so that it does not come into contact with direct sunlight. Otherwise, surface changes, shrinkage, discoloration, or fading may occur.
  - Heavy objects placed on the upholstery for long periods of time may leave an impression and wrinkles may become unable to be removed.

## Accessories

- Operating manual (this manual)
- Step (with adjuster)
- Flange nut (M6) 3 pieces (AB-IVFB, IVFT, IVFS)
- Installation manual
- Step Cover (AB-IVFW)
- Rubber ring

# Name of Components

## ■ Main body

Backrest (upper) removable model  
(AB-IVFS and IVFW)

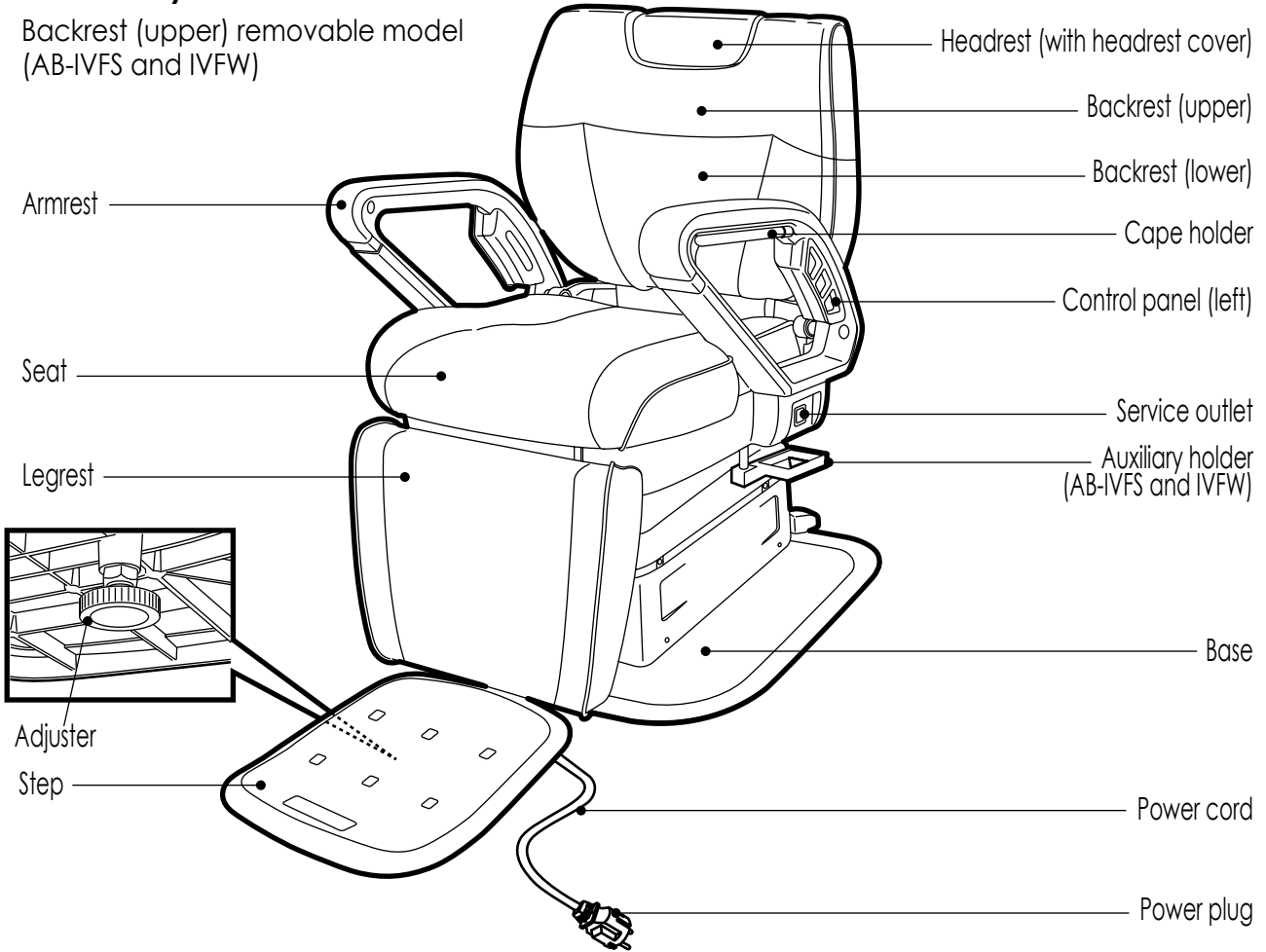

Backrest (upper) fixed model  
(AB-IVFB and IVFT)

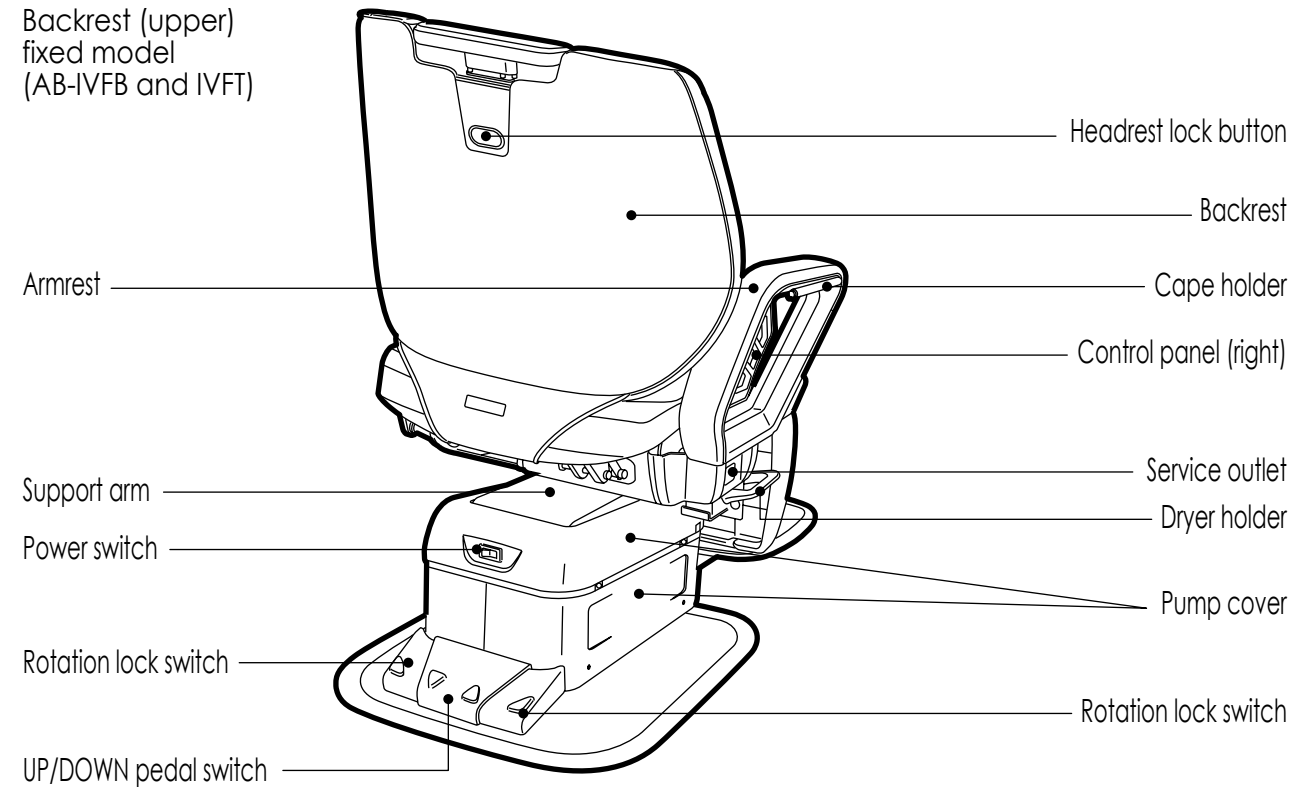

# Name of Components

## Control panel

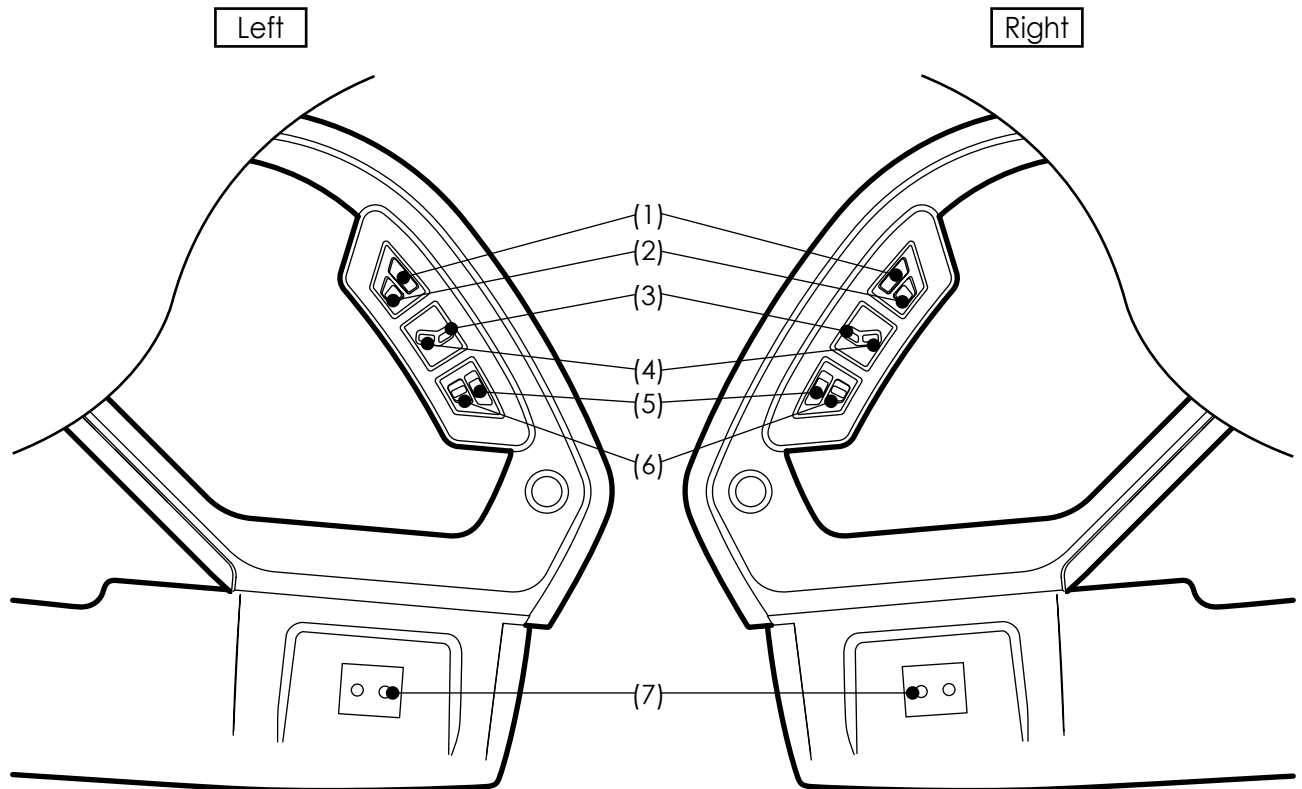

- (1) Preset switch P1
  - (2) Preset switch P2
  - (3) Backrest switch
  - (4) UP/DOWN switch
  - (5) Auto return switch
  - (6) Legrest switch (AB-IVFW, IVFT)
  - (7) Service outlet
- } Control panel

## Base operation unit

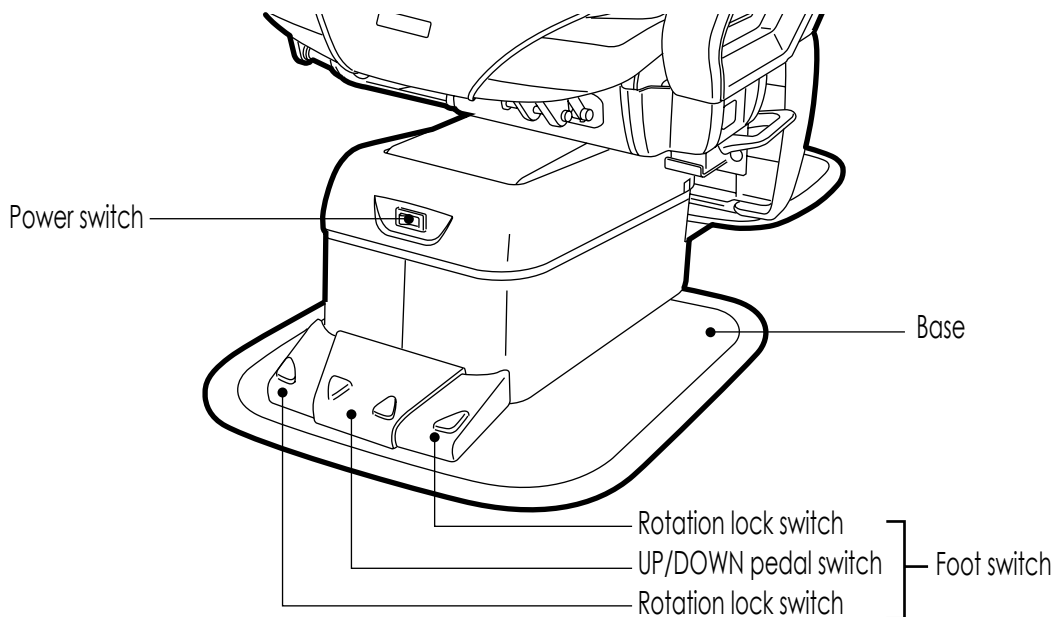

# Preparation

## ■ Power Supply

### 1. Inserting the power plug to the outlet

#### ⚠ Warning

- Be sure to plug the power cord into an outlet of 230 VAC (7A or higher)\*. Do not share the outlet with other appliances.  
※ 240 VAC (7A or higher), 220 VAC (7A or higher), 120 VAC (12A or higher), and 110 VAC (12A or higher)
- Insert the power plug completely to the end. Do not unplug the power cord by pulling on the cord. Instead hold the power plug when unplugging.
- Do not ground to: A gas pipe, water pipe, lightning rod, or telephone grounding.
- Wiring must be performed by a qualified electrician. Consult a qualified specialist.
- The supply cord must be replaced by the manufacturer or its service agent or similarly qualified person.



Be sure to ground the product. This can prevent electric shock.

#### Type C Specification

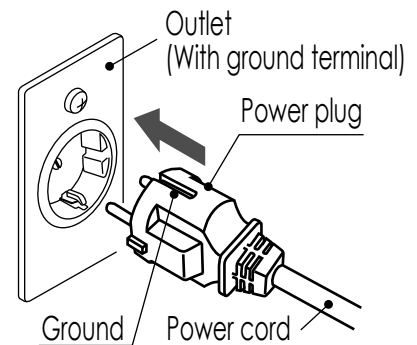

#### Type BF Specification

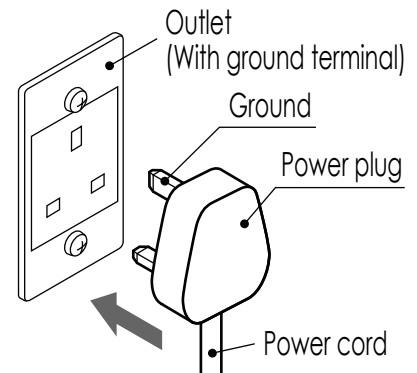

### 2. Turning on the power

The power switch is provided in the base operation unit. Pressing **||** mark side of the switch will turn on the power. Pressing **◎** mark side of the switch will turn off the power.

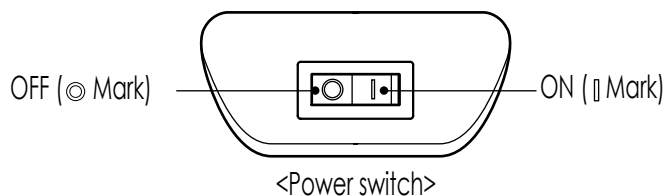

⇒ When the chair rotation is not locked, the chair rotation is automatically locked when turning on the power.

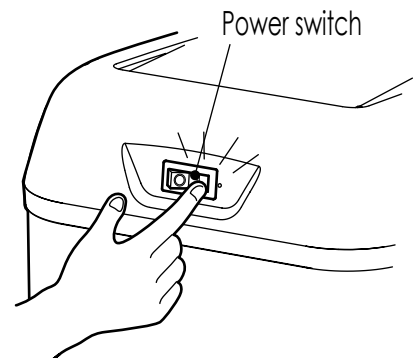

#### ⚠ Warning

Unplug the power cord when not used for a long period of time such as on holidays or at the end of the day.

#### NOTES

- Turn on or off the main switch by hand.
- The chair rotation is locked when turning on the power.



# How to Use

## (1) Using the Rotation Lock Switch and Cape Holder

### 1. Rotate the chair so that your customer can be easily seated on the chair.

#### 1 Depress the rotation lock switch.

The chair can be rotated freely by depressing the lock switch (either left or right button). Hydraulic pressure is used for the rotation lock. Depressing the rotation lock switch switches rotation lock and rotation unlock.

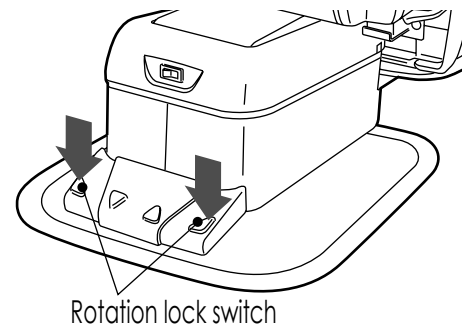

#### 2 Rotate the chair.

Turn the chair by holding the backrest or the armrest. (The chair turns 360°.)

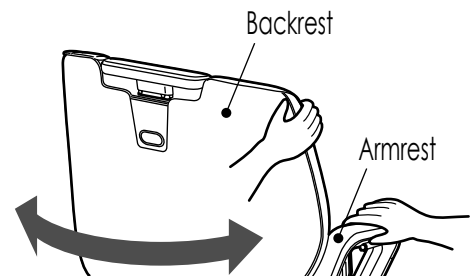

#### 3 Lock the chair.

Stop the chair at the working position and then depress the rotation lock pedal. The chair is locked.

⇒ The chair rotation will be locked automatically in the following cases.

##### When turning on the power switch

When turning on the chair, the chair rotation is locked automatically.

##### When pressing any switch

When turning on or off any of switches in the base operation unit or the control panel, the chair rotation is locked automatically.

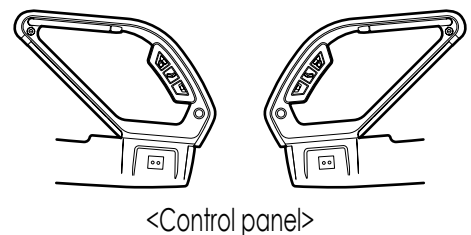
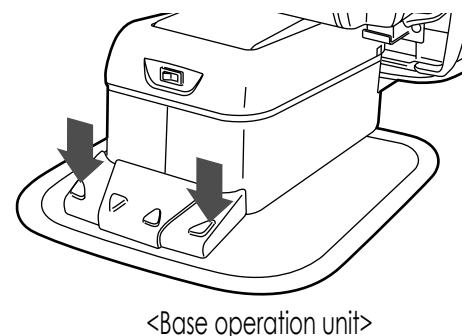

### ⚠ Caution

- Ensure that your customers always sit down or stand up from the chair at its lowest position with chair rotation being locked for safety.
- Please pay attention to the following safety cautions when rotating the chair.
  - Lower the chair at the lowest end.
  - Confirm that your customer is sitting completely on the chair before turning the chair.
  - Make sure that there are no people around the chair before turning the chair and step or other things don't hit your customers or devices.
- Lock the chair when not rotated.
- When turning on the power switch, chair rotation will be locked automatically.

# How to Use

## 2. Using the cape holder

Using the cape holder provides the following:

- Good ventilation (making space between the customer and cutting cape)
- Easy handling of cut hair

### 1 Pull out the cape holder from armrest and rotate it forward.

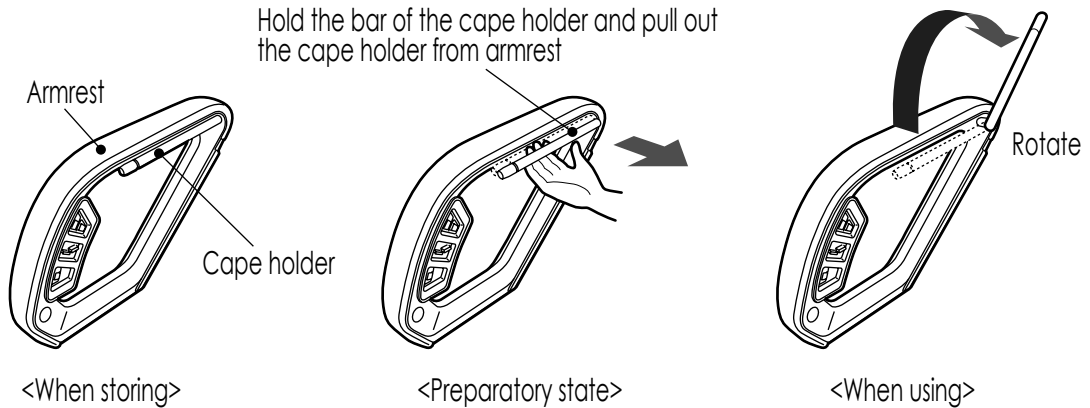

### 2 Pull the tip of the cape holder to pinch the cutting cape.

(1) Pull the tip of the cape holder from over the cutting cape.

(2) Pinch the cutting cape and release it.

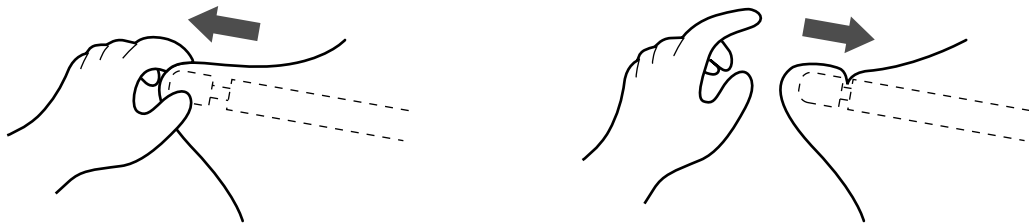

#### Caution

- Do not apply unnecessary force to the cape holder (cape holder withstand load: 10 N (1 kgf)).
- When not using the cape holder, be sure to return it to the storage position.
- When returning the cape holder to the storage position, be careful that a finger of the customer or user is not pinched between the cape holder and the armrest.

# How to Use

## (2) Raising/Lowering Chair

### 1. Raising the chair

For raising the chair, depress the right side of the UP/DOWN switch in the base operation unit or push the UP/DOWN switch of the control panel (either left or right side) upward. The chair will move while the switch is depressed (or pushed).

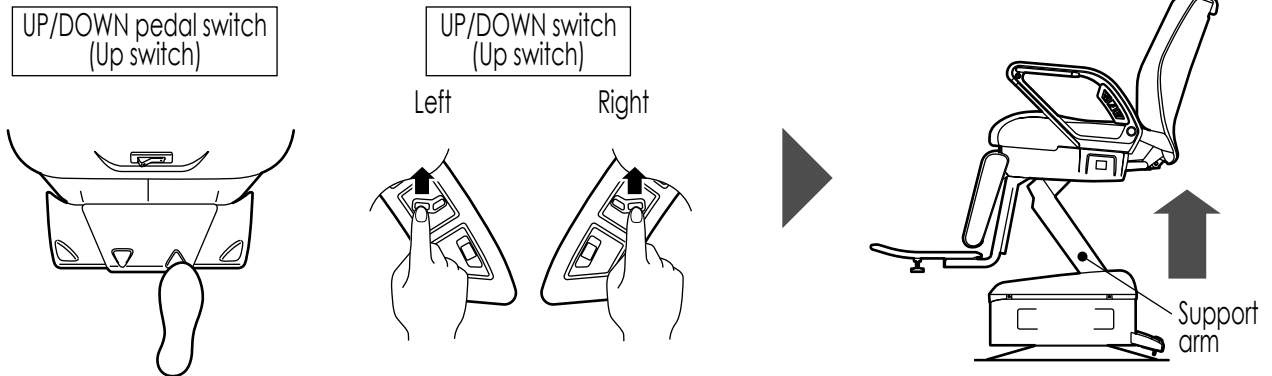

⇒ If the chair is unlocked, it is locked automatically when pressing any of the switches.

### 2. Lowering the chair

For lowering the chair, depress the left side of the UP/DOWN pedal switch in the base operation unit or push the UP/DOWN switch of the control panel (either left or right side) downward. The chair will move while the switch is depressed (or pushed).

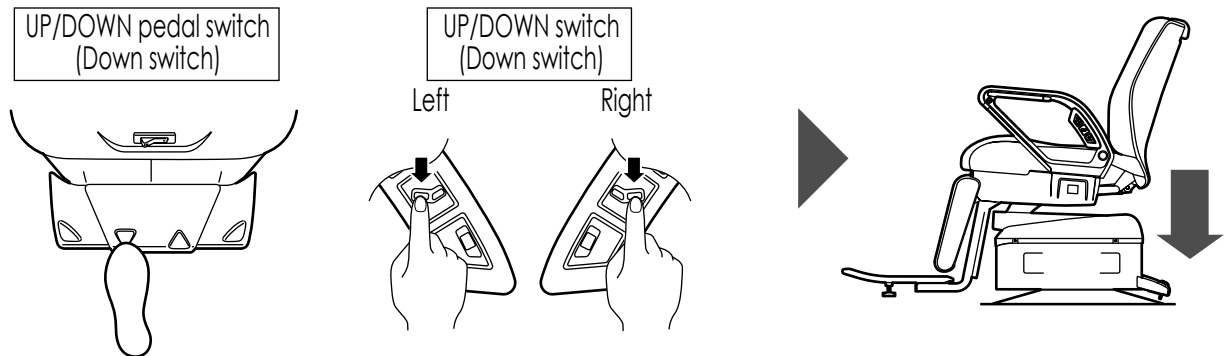

⇒ If the chair is unlocked, it is locked automatically when pressing any of the switches.

#### **⚠ Warning**

- Make sure that there are no people or obstructions around the seat and the step before raising or lowering the chair. The chair is very heavy. If caught in the support portion or the step, people may be seriously injured.
- This chair moves back as you raise it. Make sure that there is no obstruction forward and backward before raising the chair.

# How to Use

## (3) Adjusting the Headrest, Backrest, and Legrest

### 1. Pulling up the headrest

It is not necessary to use the headrest when the head of a customer does not need to be supported such as back shampoo.

#### 1 Insert your hand between the headrest and the backrest and then pull up the headrest.\*

The headrest will be locked at the position where you release it.

\* The maximum pulling out position is marked on the headrest support frame by (—) mark. When pulling up the headrest support frame further than this position and removing it completely from the backrest, insert the headrest support frame into the slot from which you removed it while pushing the headrest lock button.

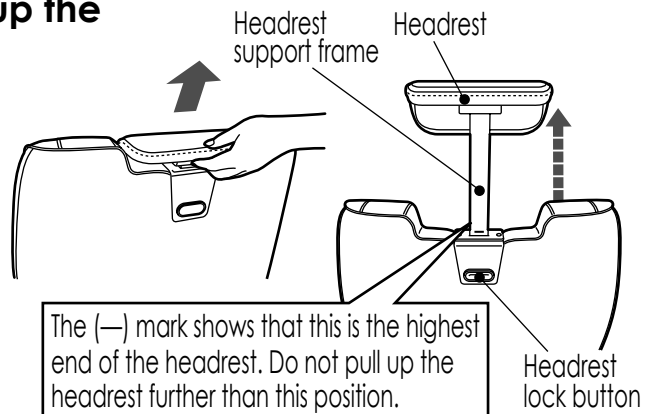

#### 2 Return the headrest to the original position when you finish using it.

While pressing the headrest lock button, depress the headrest. When returning the headrest, be sure to hold the headrest as shown in the picture.

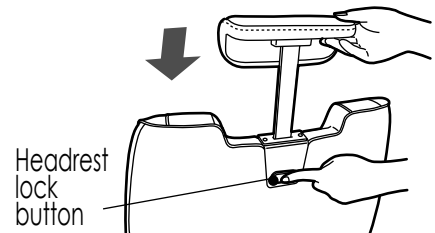

### ⚠ Caution

- Make sure that there are no obstructions around the chair when turning the chair around with the headrest being raised.
- The (—) mark shows that this is the highest end of the headrest. Do not pull up the headrest further than this position.
- Take care so that the support frame portion will not be splashed with water or liquid cosmetics. If the support portion is splashed, wipe it off immediately. If rust occurs or frictional force decreases, the headrest may not be locked sufficiently.
- Do not apply excessive weight to the raised headrest or pound it. This may cause failure of the equipment.
- When returning the headrest, be sure to hold the headrest. Take care not to have your fingers, hands, etc pinched between the headrest and backrest.
- As to the backrest removable models, do not pull out the headrest with the backrest being reclined. The upper backrest may fall.

# How to Use

## 2. Reclining the backrest

Press the backrest switch of the control panel (either left or right side) downward for reclining the backrest. The backrest continues reclining while the switch is pressed



⇒ If the chair is unlocked, it is locked automatically when pressing any of the switches.

### **Warning**

- When reclining the backrest, space between the backrest and the seat becomes smaller. Make sure that the customer's arm or hand is not placed between the backrest and the seat before reclining the backrest.

## 3. Raising the backrest

Press the backrest switch of the control panel (either left or right side) upward for raising the backrest. The backrest continues rising while the switch is pressed.



⇒ If the chair is unlocked, it is locked automatically when pressing any of the switches.

### **Warning**

Make sure that the customer's elbow or hand is not placed between the backrest and the armrest before raising the backrest.

Preset function will move the backrest and the legrest to the preset position. Refer to "(4) Preset Function and Auto Return Function".

# How to Use

## 4. Raising the legrest (AB-IVFW, AB-IVFT)

Press the legrest switch of the control panel (either left or right side) upward for raising the legrest. The legrest continues rising while the switch is pressed.



⇒ If the chair is unlocked, it is locked automatically when pressing any of the switches.

## 5. Lowering the legrest (AB-IVFW, AB-IVFT)

Press the legrest switch of the control panel (either left or right side) downward for lowering the legrest. The legrest continues lowering while the switch is pressed.

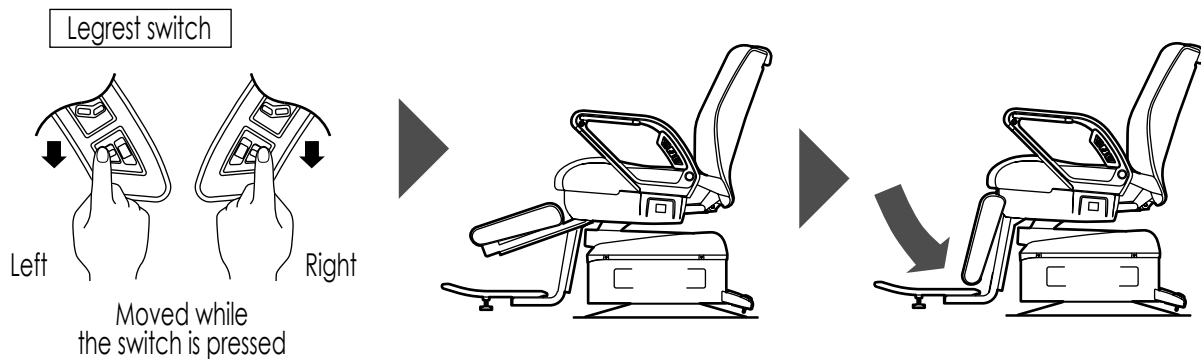

⇒ If the chair is unlocked, it is locked automatically when pressing any of the switches.

**⚠ Warning** Make sure that there is no people or obstruction under the legrest before lowering the legrest.

Preset function will move the backrest and the legrest to the preset position. Refer to "(4) Preset Function and Auto Return Function".

# How to Use

## (4) Preset Function and Auto Return Function

### 1. Using the preset function

Preset function: The seat is raised and the backrest is reclined to the preset position automatically with a press of the switch. You can set two preset positions to this chair.

- 1 If you use the headrest, pull up the headrest to a desired position beforehand.
- 2 Press the preset switch on the control panel (right/left).  
The chair will move to the preset position automatically.

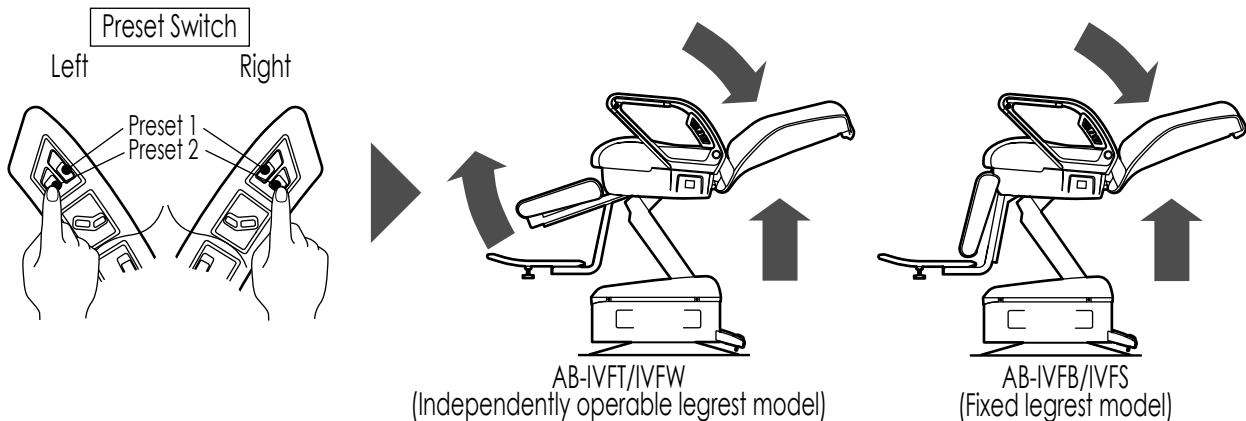

⇒ If the chair is unlocked, it is locked automatically when pressing any of the switches.

### <How to change the setting of preset function>

The preset positions of the seat, backrest and legrest are initially factory-set. However, those are changeable. Follow the steps below to change the preset positions.

1. Move the seat, backrest and legrest to desired positions.
2. Turn off the power. Then, turn on the power while pressing the preset switch (P1, P2).
3. Keep the preset switch pressed for about 3 seconds. The beep indicates that preset positions are set.
4. The beep indicates that setting of the preset positions is completed. Move the seat, backrest and legrest to the original positions by using the auto return switch. And then, use the preset switch to confirm the setting of the new preset positions.

**Warning** Care must be taken in setting the position of the legrest so that your customer's feet don't hit devices around the chair.

### 2. Using the auto return function

Press the auto return switch on the control panel (right/left). The height of the seat, the angle of the backrest, and the position of the legrest move to the initial positions automatically. (For safety, the chair starts to move after beep.)

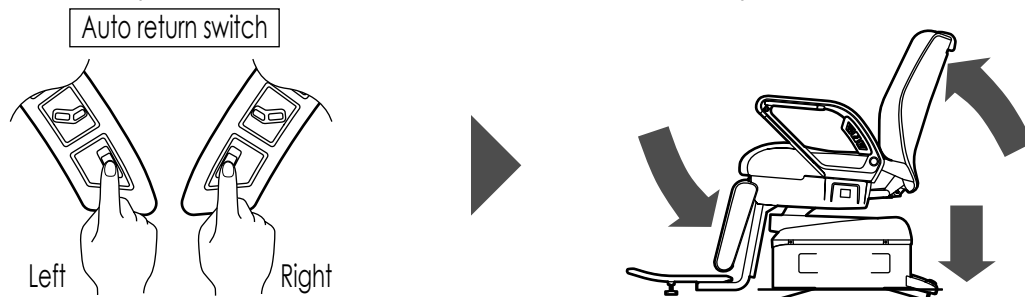

⇒ If the chair is unlocked, it is locked automatically when pressing any of the switches.

**Warning** Make sure that there are no people or obstructions under the legrest and the step, and around the support arm part before using the auto return function.

# How to Use

## Cancel function

If you want to stop the automatic operation of the chair using the preset switch or the auto return switch, pressing either switch can stop the operation. The cancel function works, and the operation will stop. (A "beep" sound is heard only when the auto return function is canceled by pressing the preset switch.)

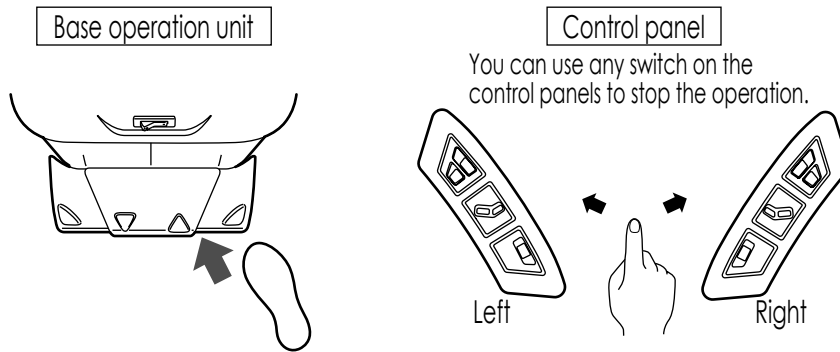

## (5) Using the Removable Step (AB-IVFW)

The step can be removed for a customer in a wheelchair, etc. When you remove the step, raise the legrest so that you can see the guide part.

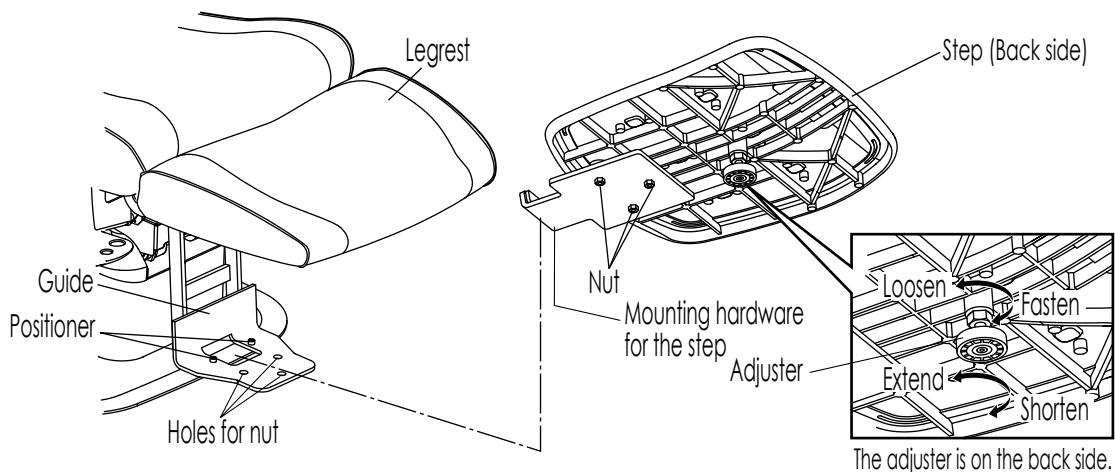

### 1 Remove the step.

Remove the mounting hardware from the guide to remove the step.

### 2 Mount the step.

Engage the hardware to the guide placing it to the positioner. Insert the nuts of the step (back side) to the holes securely.

### ⚠ Warning

- After mounting the step, make sure that the mounting hardware is securely engaged in the guide, the nuts are inserted to the holes, and there is no wobble in the step. If there is any wobble, the step may not be stable when your customers step up to or step down from the step. Also, when raising the legrest, it may rub against the upper side of the step.
- Make sure that the legrest is raised when mounting or detaching the step.
- Care must be taken when carrying or placing the step since it is very heavy. Falling accident may result in severe injury.

### ⚠ Caution

Care must be taken when extending the adjuster so that it will not touch the power cord when the chair is rotated.



# How to Use

## (6) Using the Dryer Holder

Swing out the dryer holder from the lower part of the armrest (right).

Use the dryer holder as the temporary holder of a hand dryer or hair iron during work.

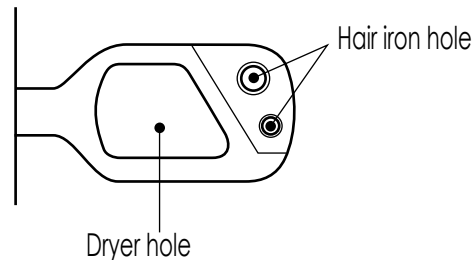
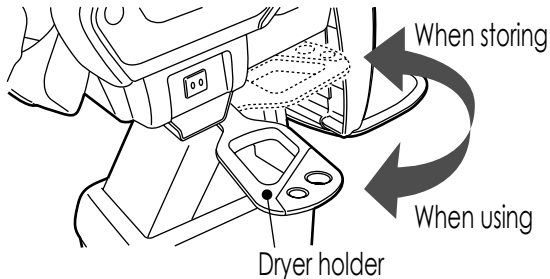

### ⚠ Caution

- Care must be taken to ensure that the holder does not hit your customer's feet, etc. when using it.
- When not using the dryer holder, be sure to return it to the storage position because the holder could hinder your work.
- Do not return or rotate the dryer holder when the hand dryer is in the holder. The chair body might be scratched or damaged by heat.

## (7) Detaching the Backrest (The Backrest (upper) removable model) AB-IVFS and IVFW

The upper backrest of the backrest removable models can be removed for children or longhaired customers.

- 1 Pull up the upper backrest to remove it.

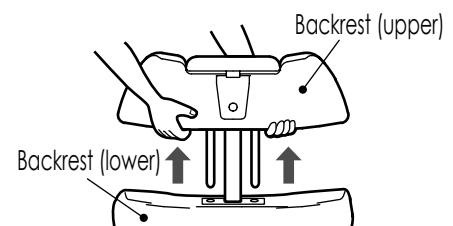

- 2 Store the backrest to the auxiliary holder on left side of the seat frame as shown in the picture.

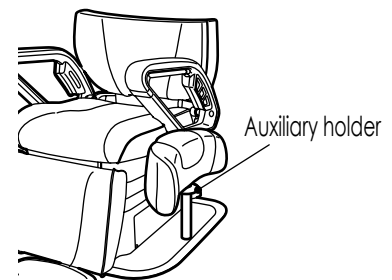

- 3 To re-attach the upper backrest, slide the three mounting hardware into the three slots of the lower backrest as shown in the picture.

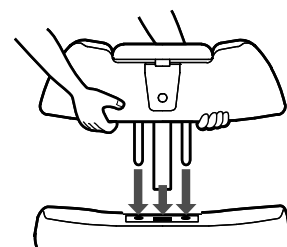

### ⚠ Caution

- When attaching the upper backrest, be careful that a finger, hand, etc. is not pinched between the upper backrest and the lower backrest.
- When detaching the upper backrest, do not recline the backrest. It may cause bodily harm due to falling over, property damage, etc.

# How to Use

## (8) Using Service Outlet

**Service outlets are provided on the both control panels (230V, 7A).\***

When the chair is not operated, the total current of the service outlets on the both sides is 7A or less. Meanwhile, when the chair is operated, the total current of the service outlets on the both sides is 4A or less. If it exceeds the limit, the main power of the chair will be turned off automatically. When it happens, stop using the appliance plugged, and then turn on the power switch of the chair again.

※240 VAC (7A or less), 220 VAC (7A or less),  
120 VAC (12A or less), and 110 VAC (12A or less)

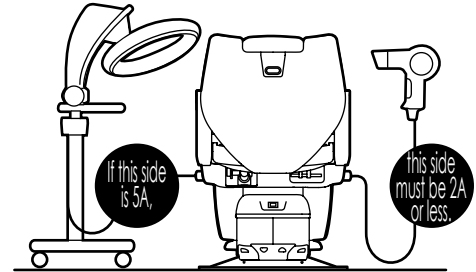

### **Warning**

When using the service outlet, the plug may be overheated and catch fire if the plug of the appliance is not correctly plugged in or retention ability of the outlet weakens. If it happened, stop using the appliance immediately, turn off the power of the appliance, and unplug the power cord of the appliance from the service outlet. Also, stop using the chair, turn off the power, unplug the power cord, and contact your dealer or us.

This product is designed for commercial use at barbers or beauty salons. Make sure that the product is operated by experienced barbers or hairdressers, or under the supervision by them.

# Care and Maintenance

Take care of the product after use and keep it always clean. If the product remains dirty, it may get moldy. When you clean the product, be sure to unplug the power cord from the outlet.

## ■ Maintenance of each section

### Leather

Wipe the surface with soft and dry cloth gently.



If the stain is heavy

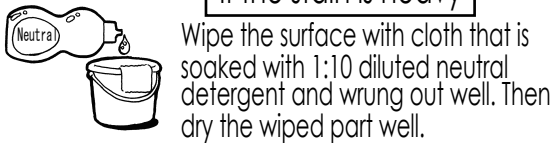

Wipe the surface with cloth that is soaked with 1:10 diluted neutral detergent and wrung out well. Then dry the wiped part well.

### Resin

Wipe the surface with soft and dry cloth.



If the stain is heavy

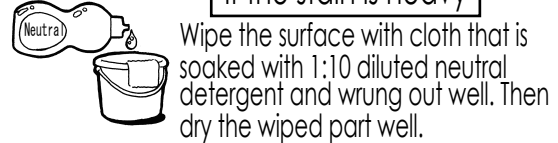

Wipe the surface with cloth that is soaked with 1:10 diluted neutral detergent and wrung out well. Then dry the wiped part well.

### Metal

Wipe the surface with soft and dry cloth gently.



Do not wipe the metal with wet cloth because the metal hates humidity and water. If the metal is watered, wipe out moisture immediately. Moisture causes rust and a failure of the electric components.

- Never use the following for cleaning:  
Volatile chemicals such as thinner, alcohol, polish remover, gasoline, or kerosene; abrasive wax; abrasive sponges, etc.

### Notice ⚠ Caution

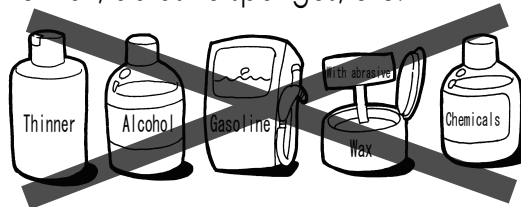

Do not use brushes, scrubbing pad, or equivalents for cleaning. They scratch the surface of the product and the stain becomes hard to remove.

### ⚠ Warning

- This product is electric equipment. Do not splash water on the product for cleaning. It may cause failure or electric shock.
- When cleaning the product, turn off the power and unplug the power cord. Otherwise, this may cause electric shock or fire. Also if the product moves during cleaning, it may result in bodily injury.

### ⚠ Caution

- Do not clean leather parts with detergent including organic solvent or abrading agent, bleaching agent, and equivalents. It may cause deterioration of the surface and texture and gloss of the surface may be disfigured.
- If the color of clothing or a belt remains in the upholstery, wipe it out with 1:10 diluted neutral detergent promptly to avoid color infiltration.

To use the equipment that has not been used for a long time, clean before using and be sure to check that the equipment operates safely without any error.

# Daily Inspection

To ensure safe use, inspect the product according to "Daily Inspection Procedure" in Page 20 in this manual.



Be sure to inspect the product by following the description of "Daily Inspection Procedure." Using the product without conducting daily inspection may cause breakdown or accident.

# Troubleshooting

Please conduct inspection on your own before contacting your service agent or us.

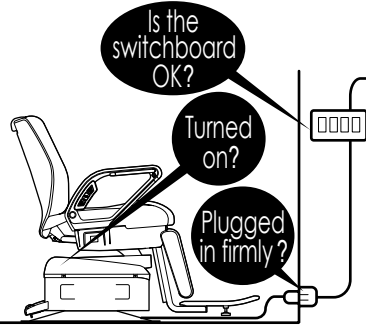
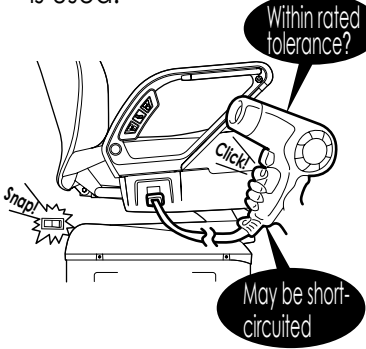
Trouble	Possible cause	Possible countermeasures
<p>■ The chair is not activated.</p> 	<ul style="list-style-type: none"> <li>■ Is the power cord correctly plugged in?</li> <li>■ Is the power switch turned on?</li> <li>■ Is the fuse or the breaker of the switchboard connected?</li> <li>■ Has the equipment operated for a long period of time continuously?</li> </ul>	<ul style="list-style-type: none"> <li>■ Plug the power cord to the outlet correctly (see Page 7).</li> <li>■ Turn on the power (see Page 7).</li> <li>■ Turn on the fuse or the breaker of the switchboard.</li> <li>■ The overheat prevention device has been activated.                             <ul style="list-style-type: none"> <li>⇒ Allow the equipment rest for about 10 minutes. The operation will resume after that.</li> </ul> </li> </ul>
<p>■ The main switch is turned off when the service outlet is used.</p> 	<ul style="list-style-type: none"> <li>■ Is the total current consumption with rated tolerance?</li> <li>■ Is the appliance plugged in the service outlet working without short-circuit?</li> </ul>	<p><b>Overheat prevention device</b></p> <p>A protection circuit to prevent abnormal overheating of the inner mechanism due to continuous operation. When this device is activated, the equipment will not operate temporarily.</p> <ul style="list-style-type: none"> <li>■ When total current consumption exceeds the rated tolerance, the breaker function starts to work. Decrease your current consumption to be within tolerance and turn on the power. The operation will resume after that (See Page 17).</li> <li>■ Test this using a different apparatus. If the power switch is still turned off when the service outlet is used by a different apparatus, please contact your dealer or us.</li> </ul> <p><b>Breaker function</b></p> <p>The power switch also functions as a breaker. If the appliance is short-circuited or the current consumption exceeds the rating, the power switch is automatically turned off. Turn on the power after the fault condition is cleared. The operation should resume.</p>

## The following is not trouble.

■ Abnormal sound is heard at startup.

■ This is a phenomenon caused when the inner lubricant oil is cooled. The equipment functions normally. The sound will disappear after a while.

When the operation does not resume after checking the possible causes and taking possible countermeasures, please refrain from using the chair, turning off the power, and unplug the power cord, and contact your dealer or us.

# Daily Inspection Procedure

Follow the inspection procedure below to ensure safe and long use of the product.

## ■ Items to be checked every day

Item to be inspected	How to inspect	In case of x (rejection) as a result of inspection
<input type="checkbox"/> Proper operation of the equipment	<input type="checkbox"/> Inspect that beep continues (repeating a pattern: one- to three-time beeps and short pause) when turning on the power.  <input type="checkbox"/> Inspect that the seat is raised and the backrest is reclined to the preset position by using the preset switch.  <input type="checkbox"/> Inspect that the seat and the backrest are returned to the initial positions (position at which your customers step up to or step down from the chair) by using the auto return switch.  <input type="checkbox"/> Inspect that the chair is moved up and down by using UP/DOWN pedal switches in both the control panels and the base operation unit.  <input type="checkbox"/> Inspect that the backrest is reclined and raised by using the backrest switch.  <input type="checkbox"/> Inspect that the legrest is moved up and down by using the legrest switch.  <input type="checkbox"/> Inspect that the rotation is locked and unlocked by using the rotation lock switch.	<input type="checkbox"/> Turn off the power, wait for about 5 seconds, and then turn on the power again. If you still hear the beep, the position detector may have a failure. Stop using the product, turn off the power, unplug the power cord, and contact your dealer or us.  <input type="checkbox"/> Follow the procedures in page 14, "How to Use, (4) Preset Function and Auto Return Function, 1. Using the preset function". If the operation is abnormal, stop using the product, turn off the power, unplug the power cord, and contact your dealer or us.  <input type="checkbox"/> Follow the procedures in page 14, "How to Use, (4) Preset Function and Auto Return Function, 2. Using the auto return function". If the operation is abnormal, your customers may be unable to get on and off the chair safely. Stop using the product, turn off the power, unplug the power cord, and contact your dealer or us.  <input type="checkbox"/> Follow the procedures in page 10, "How to Use, (2) Raising/Lowering Chair". If the operation is abnormal, your customers may be unable to get on and off the chair safely. Stop using the product, turn off the power, unplug the power cord, and contact your dealer or us.  <input type="checkbox"/> Follow the procedures in page 11, "How to Use, (3) Adjusting the Headrest, Backrest, and Legrest". If the operation is abnormal, your customers may be unable to get on and off the chair safely. Stop using the product, turn off the power, unplug the power cord, and contact your dealer or us.  <input type="checkbox"/> Follow the procedures in page 11, "How to Use, (3) Adjusting the Headrest, Backrest, and Legrest". If the operation is abnormal, your customers may be unable to get on and off the chair safely. Stop using the product, turn off the power, unplug the power cord, and contact your dealer or us.  <input type="checkbox"/> Follow the procedures in page 8, "How to Use, (1) Using the Rotation Lock Switch and Cape Holder, 1. Rotate the chair so that your customer can be easily seated on the chair". If the operation is abnormal, your customers may be unable to get on and off the chair safely. Stop using the product, turn off the power, unplug the power cord, and contact your dealer or us.

# Daily Inspection Procedure

Item to be inspected	How to inspect	In case of x (rejection) as a result of inspection
<input type="checkbox"/> Proper operation of the equipment  <input type="checkbox"/> Unusual smell from the equipment  <input type="checkbox"/> Oil leakage	<input type="checkbox"/> Inspect that the product does not wobble and abnormal sound does not occur during operation.  <input type="checkbox"/> Inspect that the chair stops at a specific position for a certain time and the seat does not sink down.  <input type="checkbox"/> Inspect that no unusual smell or smoke comes out from the product.  <input type="checkbox"/> Inspect that oil doesn't drop on the surface of the base of the product and does not seep through the pump cover.	<input type="checkbox"/> When the product wobble and abnormal sound occurs during operation, stop using the product, turn off the power, unplug the power cord, and contact your dealer or us.  <input type="checkbox"/> When the product does not stop at a specific position for a certain time and the seat sinks down, stop using the product, turn off the power, unplug the power cord, and contact your dealer or us.  <input type="checkbox"/> When unusual smell or smoke comes out from the product, it may cause malfunction and/or fire. Stop using the product, turn off the power, unplug the power cord, and contact your dealer or us.  <input type="checkbox"/> Oil may be leaking from hydraulic parts. Stop using the product, turn off the power, unplug the power cord, and contact your dealer or us.

# Specifications

Model name	AB-IVFB / AB-IVFS / AB-IVFT / AB-IVFW
Weight	105kg / 106kg / 114kg / 115kg
The maximum working load	1,350N(135kgf)
The number of permitted persons	1
Usage environment	Temperature 0 ~ 40°C Humidity 10 ~ 95% Air pressure 700 ~ 1060 hPa
Transportation / Storage environment	Temperature -20 ~ 70°C Humidity 10 ~ 95% Air pressure 700 ~ 1060 hPa

Rated voltage	AC240V	AC230V	AC220V	AC120V	AC110V
Rated frequency	50Hz	50Hz	50Hz / 60Hz	50Hz / 60Hz	60Hz
Rated current consumption	2.1A	2.0A	1.8A / 2.0A	5.4A / 3.9A	3.9A

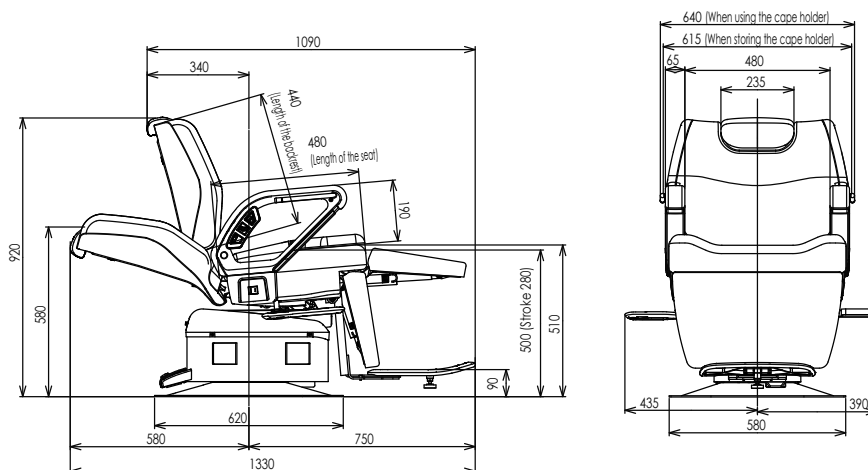

\* The sizes and specifications are subject to change without notice for future improvement.

## Standard Period of Use

- The standard period of use for this product is 10 years.
- The standard period of use acts as “a guide to the standard period of time that each product can be used safely and without trouble when under standard usage conditions, appropriate maintenance and inspection (including parts replacement) have been performed and the product has been used.” This is not a warranty period. The “standard period of use” will differ depending on an environment that the customer uses the product in and its frequency of use. For maintenance after the standard period of use has passed, consult your local dealer or TAKARA BELMONT.

## When Disposing of This Product

Properly dispose of this product or its replacement parts in accordance with the laws and regulations at the time of disposal.

**EU REPRESENTATIVE**

**TAKARA COMPANY EUROPE GmbH**  
Berner Strasse 18, 60437  
Frankfurt am Main, Germany  
Tel:+49 69 506878 0  
Fax:+49 69 506878 20

**MANUFACTURER**

**TAKARA  
BELMONT**



**TAKARA BELMONT CORPORATION**  
2-1-1, Higashishinsaibashi, Chuo-ku, Osaka, 542-0083, Japan  
TEL:81-6-6212-3523  
FAX:81-6-6211-5745

BOOK.No : 1E02MJEE  
Original instruction